

OPERATOR'S MANUAL

RCW 1500W SERIES

POWER SUPPLY

SINGLE OUTPUT, UNIVERSAL INPUT
SINGLE PHASE, 0.99 POWER FACTOR

KEPCO INC.
An ISO 9001 Company.

MODEL

RCW 1500W SERIES

POWER SUPPLY MODELS

**RCW 3.3-300K, RCW 5-300K, RCW 12-125K,
RCW 15-100K, RCW 24-65K, RCW 28-55K,
RCW 48-32K**

IMPORTANT NOTES:

- 1) The contents of this manual are protected by copyright. Reproduction of any part can be made only with the specific written permission of Kepco, Inc.
- 2) Data subject to change without notice.

©2004, KEPCO, INC
P/N 228-1502



KEPCO, INC. • 131-38 SANFORD AVENUE • FLUSHING, NY. 11352 U.S.A. • TEL (718) 461-7000 • FAX (718) 767-1102
email: hq@kepcopower.com • World Wide Web: <http://www.kepcopower.com>

TABLE OF CONTENTS

SECTION		PAGE
1.0	Introduction.....	1
1.1	Scope of Manual	1
1.2	Description	1
2.0	Specifications	1
3.0	Operation.....	4
3.1	Installing The Power Supply	4
3.2	Connecting The Load (Local Sense).....	7
3.3	Connecting The Load (Remote Sense).....	7
3.4	Voltage Adjustment	7
3.5	Remote Voltage Control	8
3.6	Remote Turn-on Turn-off.....	9
3.7	Parallel Operaton	9
3.8	Master/Slave Operation.....	11
3.9	Preliminary Electrical Check.....	11
4.0	Alarm Functions	13
4.1	Overvoltage And Overtemperature Protection	13
4.2	Undervoltage Protection	14
4.3	PF Input Power Failure.....	14
4.4	Fan Failure	15
5.0	Fan Replacement	15
6.0	Fan Maintenance.....	15

LIST OF FIGURES

FIGURE	TITLE	PAGE
1	RCW 1500W Power Supply Peak To Peak Input Surge Current For T<50us	3
2	Percent Power Rating Versus Ambient Temperature	4
3	Mechanical Outline Drawing OfThe RCW 1500W Power Supply	5
4	Mounting Positions For The RCW 1500W Power Supply.....	6
5	Connections For Remote Sensing With The RCW 1500W Power Supply.....	7
6	Terminal Locations Of The RCW 1500W Power Supply.....	8
7	Connections For Remote Voltage Control Of The RCW 1500W Power Supply	9
8	Parallel Connection of Three RCW Power Supplies	10
9	Functional Checkout Of The RCW 1500W Power Supply	12
10	Logic Alarm Optical Coupler Output For The RCW 1500W Power Supply.....	13
11	Timing Diagrams For The RCW 1500W Power Supply	14

LIST OF TABLES

TABLE	TITLE	PAGE
1	Power Supply Ratings And Specifications	1
2	Power Supply Ratings and Specifications	2

1.0 INTRODUCTION

1.1 SCOPE OF MANUAL

This Operator's Manual covers the installation and operation of the Kepco RCW 1500W Series of Switching Power Supplies. For service information, write directly to: Kepco Inc., 131-38 Sanford Avenue, Flushing, New York, 11352, U.S.A. Please state Model Designation and Serial Number of your RCW Power Supply. This information can be found on the nameplate of the unit.

1.2 DESCRIPTION

The Kepco RCW 1500W Series consists of seven models of Switching Power Supplies, with a single output as shown in Table 1. RCW power supplies are compliant with the Low Voltage Directive (LVD) and carry the CE Mark. Units are designed to operate with a universal input voltage within the range of 85 to 264V AC and may be operated with either 100-120V AC, or 200-240V AC, 50-60 Hz (47-66 Hz) input. They will also operate on 125V to 370V dc input. The RCW 1500W Series employs a light weight ferrite core transformer with 150 KHz typical switching frequency. The Power Factor Correction Circuit has a typical switching of 80 KHz. Regulation is provided by pulse width modulation. A FET power stage, operating in the forward conversion mode provides a smooth isolated dc output. A resistor and thyristor "soft-start" circuit prevents excessive turn-on current surge. Overvoltage protection and optically isolated remote TTL ON-OFF control are provided. Current limiting with automatic recovery from short circuit is featured. Units are enclosed in a wrap-around aluminum case with a green LED "output present" light visible on the terminal side of the case.

2.0 SPECIFICATIONS

Table 1 contains specifications and operating limits of individual RCW 1500W Series models. Table 2 contains specifications and operating limits common to all RCW 1500W Series Models. These specifications are at nominal input voltages at 25°C unless otherwise specified.

TABLE 1. POWER SUPPLY RATINGS AND SPECIFICATIONS

MODEL RCW 1500W		3.3-300K	5-300K	12-125K	15-100K	24-65K	28-55K	48-32K
Output Volts d-c ⁽⁵⁾		3.3V	5V	12V	15V	24V	28V	48V
Adjustment Range ⁽⁷⁾		1.8-3.5	3.5~5.5	8.4~13.2	12.0~16.5	16.5~26.4	25.2~30.8	30.8~52.8
Maximum Output Ratings (Amps/ Watts)	50°C, amb A	300	300	125	100	65	55	32
	50°C, amb W	1050	1500	1500	1500	1560	1540	1536
	60°C, amb A	210	210	87.5	70A	45.5	38.5	22.4
	60°C, amb W	735	1050	1050	1050	1092	1078	1075.2
	70°C, amb A	120	120	50	40	26	22	12.8
	70°C, amb W	420	600	600	600	624	616	614.4
Current Limit (Amps) ⁽¹⁾		315-350	315-350	130-140	105-115	68-72	57.7-63.2	33.6-36.8
OVP Settings (Volts) ⁽²⁾		3.96-4.62	6.0-7.0	13.2-15.6	16.5-19.5	26.4-31.2	30.8-36.4	49.44-59.04
Efficiency % typical	AC Input 120V	70	75	76	76	78	79	80
	AC Input 240V	73	80	81	81	82	83	84
Ripple & Noise ⁽³⁾ (mV, p-p)	output ripple (max)	100	100	100	100	100	100	100
	spike noise (max) ⁽⁴⁾	200	200	200	200	200	200	300
Transient Recovery ⁽⁶⁾	Recovery to 1%(<ms)	1	1	1	1	1	1	1
	Excursion ±V max	1.0	1.0	1.0	1.0	1.0	1.0	1.0

¹⁾The Power Supply has a square type overcurrent characteristic, shutdown by undervoltage detection

²⁾The Power Supply has a shut-down type (by tracking) overvoltage characteristic. Recovery time to reset 40 seconds minimum

³⁾Source component 2x source frequency and switching component approximately 150 KHz, 10 to 100% load and ambient Ta = 25°C

⁴⁾Measure with a 50MHz bandwidth, 10 to 100% load and ambient Tc= 25°C

⁵⁾Output voltage setting = ±1%

⁶⁾A step load change from 50% to 100% of rated load current (with the following tr, tf load changes) produces no more than the output voltage excursions listed in the above table. The load change will be 5A/μs for I_o>20A and 1A/μs for I_o<20A tr, tf of load change: 3.3v and 5v>30μs, 12v>12.5μs, 15v>10μs, 24v>6.5μs, 28v>5.5μs, 48v>3.2μs,

⁷⁾Recommended (using internal adjustment pot, par. 3.4). Using external pot (par.3.5) range = 10% to 110% of rated output voltage.

TABLE 2. POWER SUPPLY RATINGS AND SPECIFICATIONS

SPECIFICATION	DESCRIPTION		
Input Voltage	Nominal: 100-120Vac or 200-240Vac	Range: 85-264 Vac	
	Range 125-370 Vdc		
Input Source Frequency	Nominal 50/60 Hz, Range 47-66 Hz. (At 400 Hz the leakage current exceeds the VDE safety leakage specification limit).		
Brownout Voltage	80 V ac min		
Input Current: (Maximum Load At 50°C with Nominal Output Voltage)	120V ac	22A RMS max., and 16A RMS max for the 3.3V output model	
	240V ac	11A RMS max., and 8A RMS max for the 3.3V output model	
Input Protection	Units Are Protected Against Shorts By An Input Fuse. Fuse Value 30.0A At 250 Volts		
Input Surge at 25° C from cold start; resistor and thyristor soft start circuit reduces start-up surge. (see Figure1)	120V ac	20.0A max. first surge	
	240V ac	40.0A max. first surge	
Stabilization		Typical	Maximum
	Source Effect (min - max) (85 to 132 V ac, 170 to 264V ac)	0.05% ⁽¹⁾	0.1% ⁽¹⁾
	Load Effect, measured at sensing terminals (0%-100% load change)	0.2% ⁽²⁾	0.3% ⁽²⁾
	Temperature Effect (-10° to 71°C)	0.5%	1.0%
	Combined Effect (envelope, Source, Load and Temperature)	± 0.7%	± 1.5%
	Drift (8 hours at 25°C)	0.2%	0.5%
Transient Rec'y Test Conditions MODEL / tr, tf of load change ≥ μs	3.3V/30μs, 5V/30μs, 12V/12.5μs, 15V/10μs, 24v/6.5μs, 28V/5.5μs. 48V/3.2μs		
Output Holding Time:	Output is maintained for 30 milliseconds typical upon input interruption (20 milliseconds minimum) with nominal 120 volts AC input voltage and output load at 50°C current rating.		
Start-up Time	900 msec maximum, 600 typical.		
Overvoltage Protection	When the Power Supply goes into an overvoltage condition, the output is cut OFF. To restart (reset) the unit, it is necessary to remove the AC input power, wait 40 seconds, and then to reconnect the AC input power.		
Operating Temperature:	-10 to 71°C (see Figure 2)		
Storage Temperature:	-30°C to +75°C		
Humidity:	10% to 95% relative humidity, noncondensing, Wet Bulb temperature<35°C		
Isolation (at 25°C ambient, 65% relative humidity)	Between input and case, 2500Vac for 1 minute Between input and output terminal, 2500Vac for 1 minute. Cutout current is 20mA		
Insulation Resistance: (at 25°C, 65% relative humidity)	Between output and case, input and case, and input and output, 100 Megohms minimum (500Vdc)		
Leakage Current:	1.0 mA max at 120 Vac (U.L. Method 50 to 60 Hz) 2.0 mA max at 240Vdc (VDE Method 50 to 60 Hz, two terminal connection)		
Vibration: (non-operating 1 hour on each of three axes, Power Supply is fixed on its bottom side)	5-10 Hz., 10mm amplitude, 10-200 Hz., 64.3ft./s ² (19.6M/s ²)		

TABLE 2. POWER SUPPLY RATINGS AND SPECIFICATIONS (CONTINUED)

SPECIFICATION	DESCRIPTION
1) 2 mV typ, 4mV maximum for the 3.3 volt Model 2) 10mV typ, 15mV maximum for the 3.3 volt Model	
Shock: (non-operating, 1/2 sine pulse, three shocks on each axis, Power Supply is fixed on its bottom side)	964.6ft./s ² (294M/s ²), 11ms ± 5 msec pulse duration
Input Transient:	The RCW Power Supply (with a 50 ohm termination) should operate trouble free when a 1us, 2K Volt, 50–60 Hz input is applied between the input and ground terminals.
EMI Conducted:	FCC Class A
Safety:	UL 1950 Recognized, CSA Electrical Bulletin 22.2, No. 234, Level 5 Certified and EN 60 950 (TUV) Approved, CE marked per Low Voltage Directive (LVD)
Remote Error Sensing:	The RCW 1500W Power Supply will compensate up to 0.15 Volts max per load wire for the RCW 3.3-300K, and up to 0.25 Volts per load wire for the RCW 5-300K, and up to 0.4 Volts per load wire for all other RCW Models (see Figure 5).
Remote Control ON/OFF:	"High", 2.4V to 24V (or open), unit ON "Low", 0.0V to 0.4V (or closed), unit OFF- Fan Off Source current is 1.6mA maximum The (±)RC terminals are isolated from the AC input terminal and the DC output terminals. Under normal conditions the (±)RC terminals are high, so when the function is not used the terminals should be left open.
Power Factor	0.99 typical, satisfies EN61000-3-2 Requirements
Dimensions:	4.33 in. (110 mm) x 7.99in. (203 mm) x 8.66 in. (220 mm)
Mounting:	No. M4x8 tapped holes
Maximum Screw Penetration:	0.24 in. (6 mm)
Cooling:	Forced air flow - two fans
Frame Material/Cover Material:	Aluminum
Weight:	16.53lbs. (7.5 Kg)

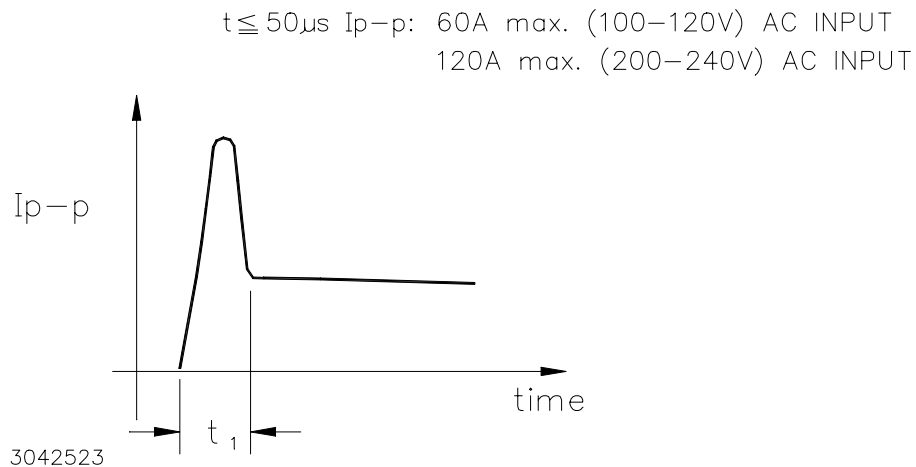

FIGURE 1 RCW 1500W POWER SUPPLY PEAK TO PEAK INPUT SURGE CURRENT FOR T<50US

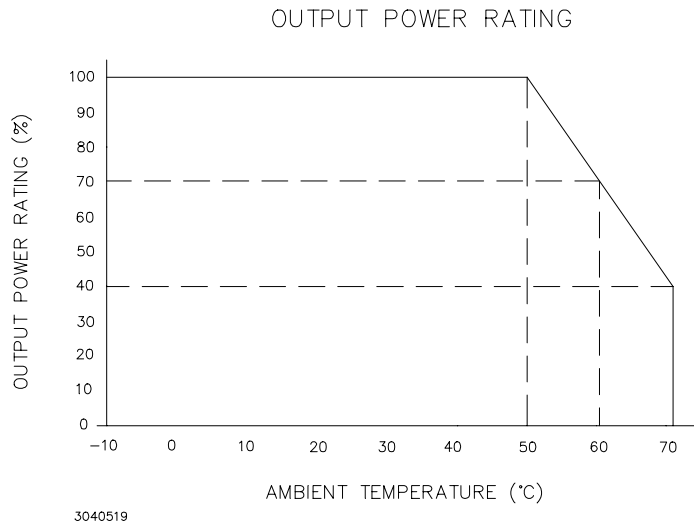

FIGURE 2 PERCENT POWER RATING VERSUS AMBIENT TEMPERATURE

3.0 OPERATION

3.1 INSTALLING THE POWER SUPPLY

The unit may be mounted in accordance with the Mechanical Outline Drawing, Figure 4 (mounting holes are provided). The temperature of the air surrounding the Power Supply must not exceed the ambient values given in the Specifications Table 1. See Figure 3 for horizontal and vertical mounting of the RCW 1500W Power Supply.

The RCW 1500W has four tapped Metric M4x8L mounting holes on the bottom side of the unit for horizontal installation as well as eight tapped Metric M4x8L mounting hole on the side surfaces for vertical installation. Free air space must be provided at the rear of the unit to allow for maximum ventilation and exhaust of the fans. Power Supply specifications should be derated for certain operating temperatures (refer to Table 2).

Referring to Figure 3, the air cooling holes on the front panel of the unit and the front of the fan and on the top cover should be kept clear at least 1 inch (20mm) from adjacent equipment and in a well ventilated area.

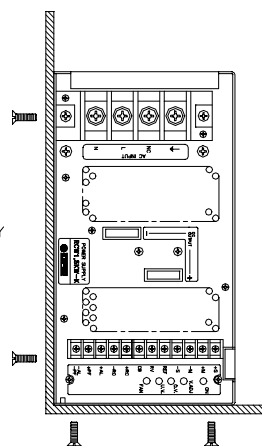
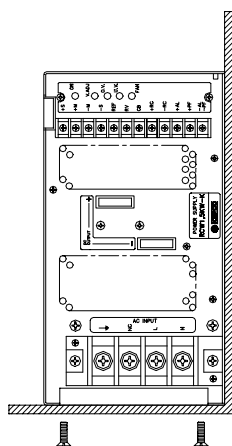
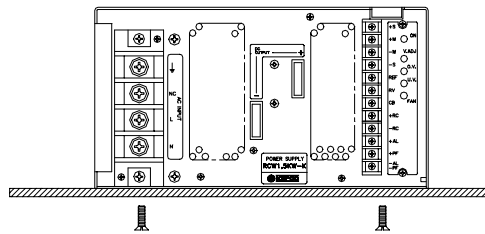
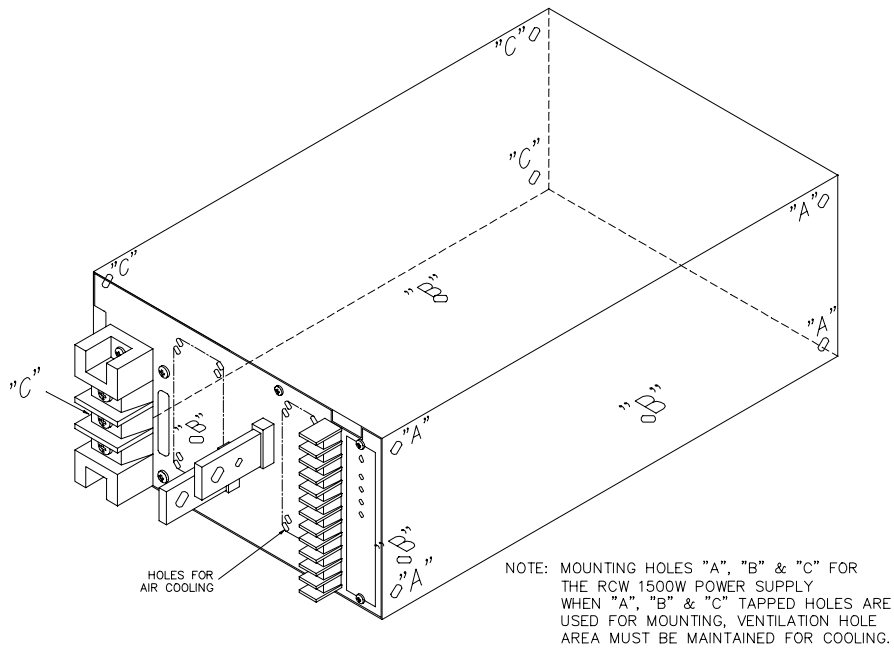

NOTE: AIR COOLING HOLES AND FANS SHOULD BE SPACED ABOUT 1 INCH (20 mm) MINIMUM FROM OTHER EQUIPMENT (IN A WELL-VENTILATED AREA.)

3041613

FIGURE 3 MOUNTING POSITIONS FOR THE RCW 1500W POWER SUPPLY

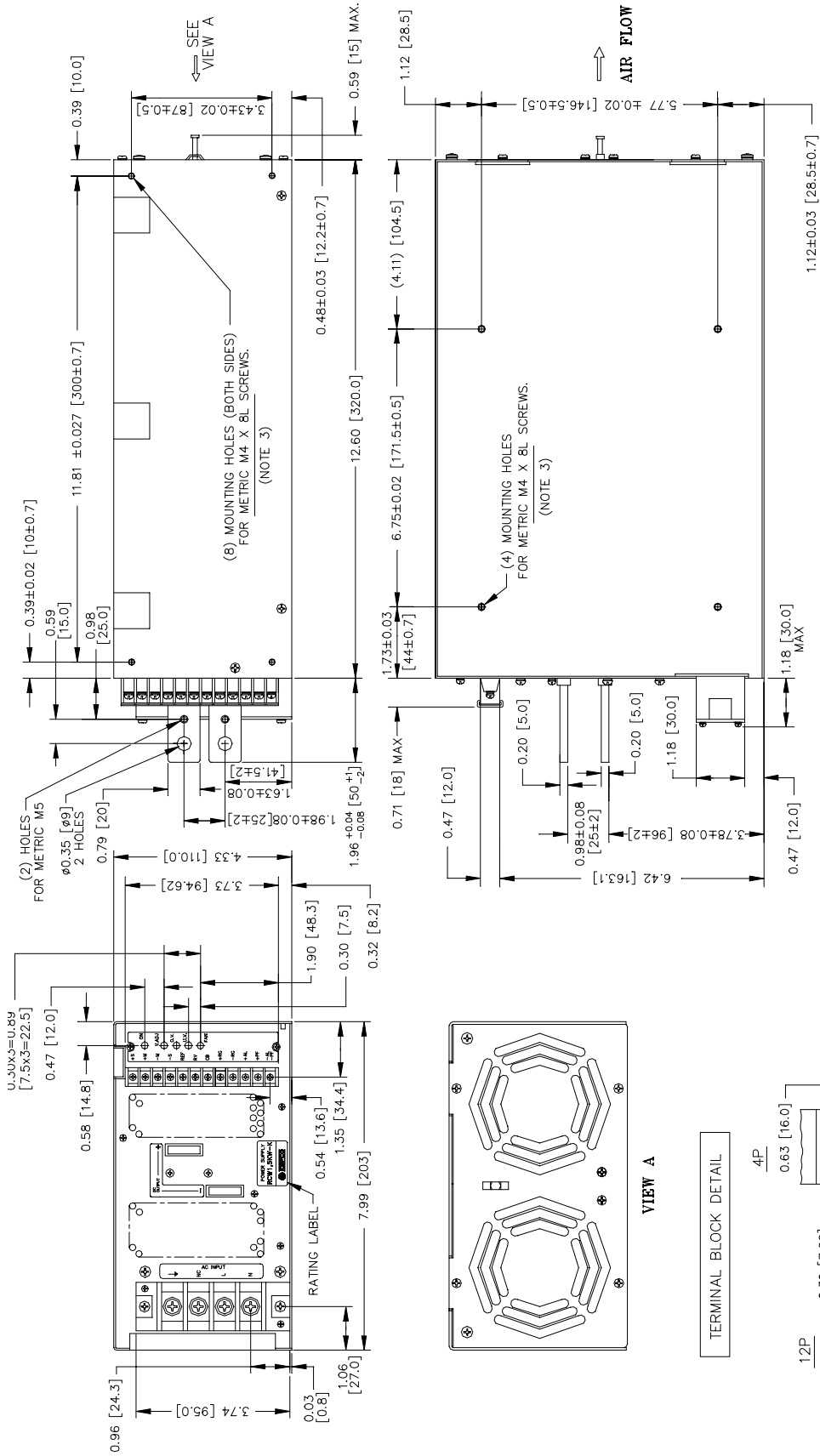

MODEL	OUTPUT
RCW 3.3-300K	3.3V --- 300A
RCW 5-300K	5V --- 300A
RCW 12-125K	12V --- 125A
RCW 15-100K	15V --- 100A
RCW 24-65K	24V --- 65A
RCW 28-55K	28V --- 55A
RCW 48-32K	48V --- 32A

- NOTES:
1. DIMENSIONS IN PARENTHESES ARE IN MILLIMETERS, OTHERS ARE IN INCHES.
 2. TOLERANCE: ±0.039 (±1mm) UNLESS OTHERWISE SPECIFIED.
 3. MOUNTING SCREWS: MAXIMUM PENETRATION OF METRIC MOUNTING SCREWS NOT MORE THAN 0.24 (6mm) FROM CASE SURFACE.
 5. MATERIAL: FRAME - STEEL; COVER - ALUMINUM.
 6. WEIGHT: 7.5 KG (16.5 LBS.) MAX.

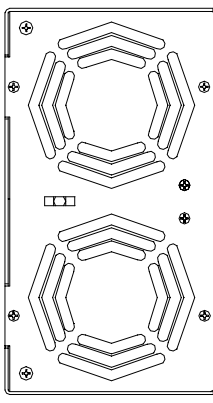

TERMINAL BLOCK DETAIL

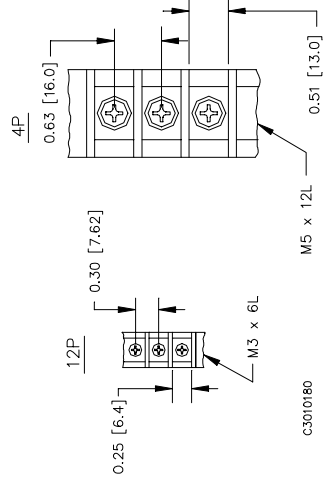

FIGURE 4 MECHANICAL OUTLINE DRAWING OF THE RCW 1500W POWER SUPPLY

3.2 CONNECTING THE LOAD (LOCAL SENSE)

To connect the load for local sensing, the shorting links must be maintained between the (+) S and (+) M terminals, and between the (-) S and (-) M terminals. The load is connected across the DC output (+) and (-) terminals.

3.3 CONNECTING THE LOAD (REMOTE SENSE)

The load is connected as shown in Figure 5. Error sensing may be done at the load terminals to compensate for voltage loss in the connecting wires. The shorting links must be removed from the (\pm) S Sense terminals.

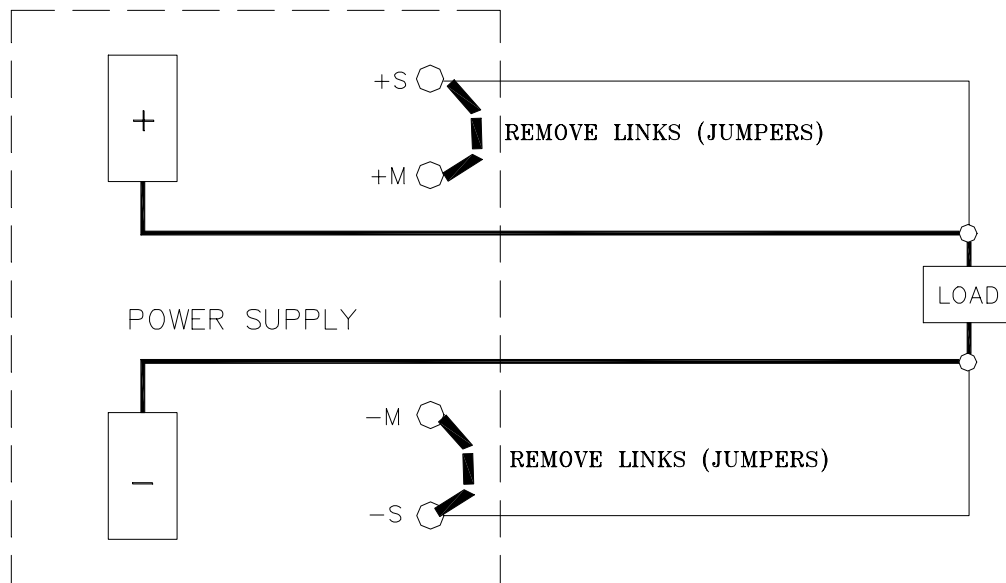

3040522

FIGURE 5 CONNECTIONS FOR REMOTE SENSING WITH THE RCW 1500W POWER SUPPLY

3.4 VOLTAGE ADJUSTMENT

The unit is provided with a voltage adjustment control (V_{adj}) (see Mechanical Outline Drawing, Figure 4). To adjust voltage, first place the unit under an operating load, then monitor the (+) S and (-) S Sense terminals with a precision voltmeter and turn the voltage control to the desired operating value. Refer to Table 1 for the recommended Adjustment Range of all the RCW 1500W Models (see Figure).

NOTE: Actual output voltage can exceed recommended range values.

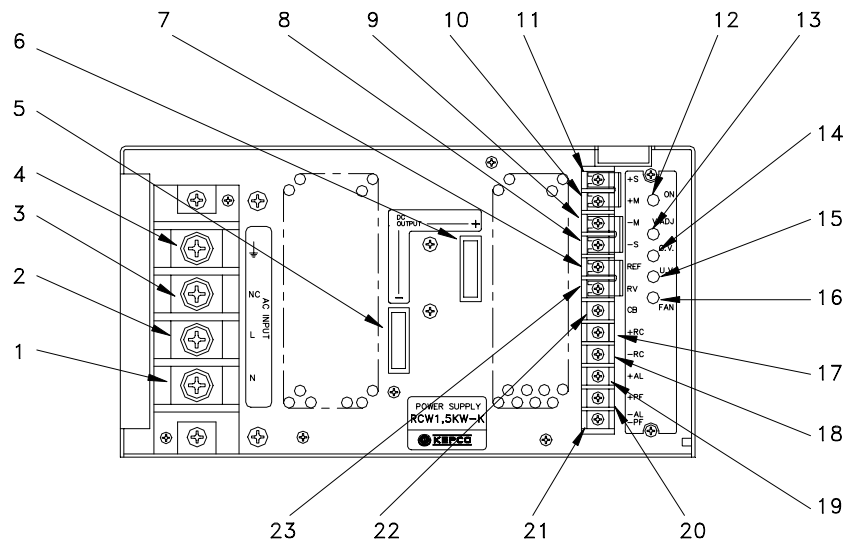

3041589

LEGEND:

- | | |
|---------------------------------------|--|
| 1. AC Input (Neutral) | 13. V. ADJ (Output Voltage Adjustment) |
| 2. AC Input (Hot) | 14. OV (Output overvoltage LED, red) |
| 3. No Connection | 15. UV (Output undervoltage LED, red) |
| 4. Ground | 16. FAN (Fan alarm LED, red) |
| 5. DC Output (-) | 17. (+) RC (Remote ON-OFF) |
| 6. DC Output (+) | 18. (-) RC (Remote ON-OFF) |
| 7. REF (Reference Voltage) | 19. (+) AL (Alarm OV, UV, Thermal,) |
| 8. (-) S (Remote Sense) | 20. (+) PF (Alarm- Input Power Fail) |
| 9. (-) M (Output Voltage Monitor) | 21. (-) AL, (-) PF (Alarm common)) |
| 10. (+) M (Output Voltage Monitor) | 22. CB (Current Balance) |
| 11. (+) S (Remote Sense) | 23. RV (Output voltage variable) |
| 12. ON (Output voltage ON LED, green) | |

FIGURE 6 TERMINAL LOCATIONS OF THE RCW 1500W POWER SUPPLY

3.5 REMOTE VOLTAGE CONTROL

The use of the RV terminal allows the output voltage to be adjusted by a trimmer pot or by an external source.

Use a shielded wire, 2m maximum in length, for connection to the trimmer control. Maintain the shorting link between the (+) S and (+) M terminals, and between the (-) S and (-) M terminals, remove links between REF and RV terminals and connect the external trimmer between the REF, RV, and (-) M and (-) S terminals (with the center lead of the trimmer going to the RV terminal, see Figure 7). Suggested value for the trimmer control is 5K ohms. **With the external trimmer**

control at its maximum clockwise position set the output voltage to the desired maximum value by adjusting the Vadj clockwise. The value should not be more than 110% Eo nominal.

By using an external 0-5.5V voltage source the maximum output voltage can be adjusted from 0 to 110%. For voltage source use remove the shorting link between the REF and RV terminal. Connect the voltage source across the RV and (-)S terminals. The impedance of the load wires connecting each power supply to the load should be the same when using remote sensing with this configuration. It is possible that the overvoltage protection may be triggered if the external programming voltage source is changed very quickly when the power supply is at a low load condition

By adjusting the external control from minimum to maximum, the output voltage will change from minimum to maximum value (0% to 110% of Eomax).

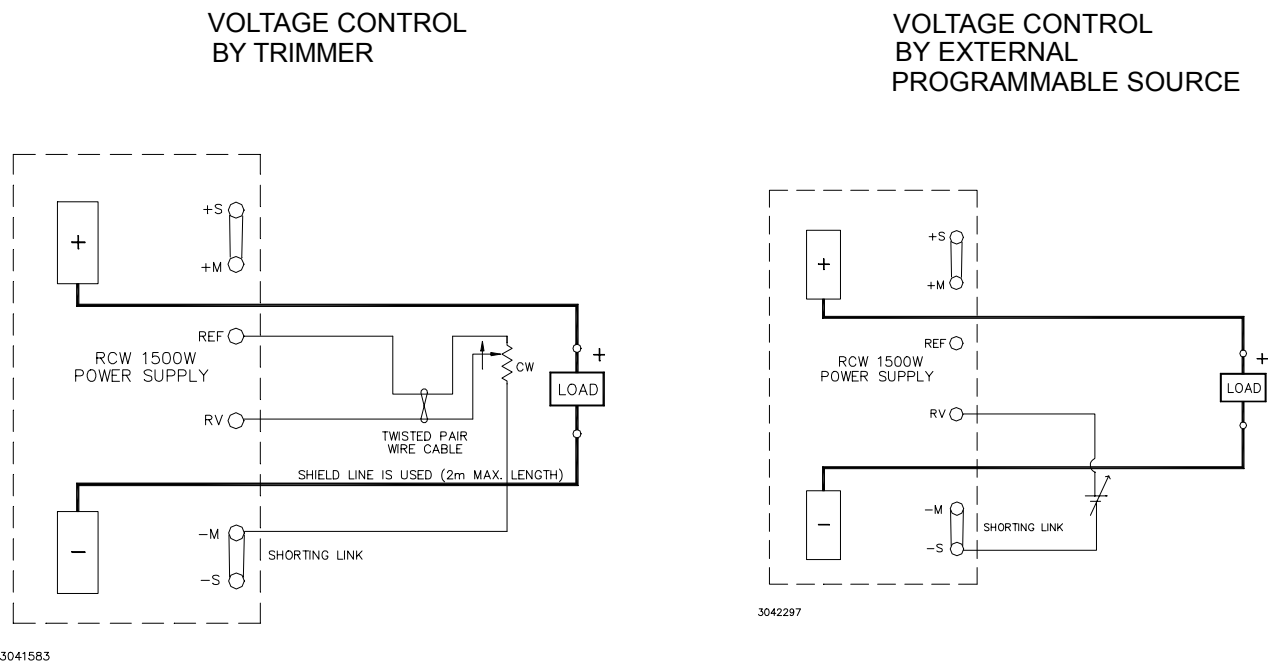

FIGURE 7 CONNECTIONS FOR REMOTE VOLTAGE CONTROL OF THE RCW 1500W POWER SUPPLY

3.6 REMOTE TURN-ON TURN-OFF

When power is ON at the source, the output may be turned ON or OFF with the remote control feature. The remote ON/OFF RC (Remote Control) terminals can be controlled by a logic level (2.4V to 24V "high" and 0.0 to 0.4V "low"), or a contact closure. When the RC terminals (on the front panel) are short circuited by using either a mechanical switch or a low level logic signal, the RCW 1500W output is cut OFF. At low level logic, the maximum sink current is 1.6mA. With the RC terminals open the RCW 1500W output returns to within specifications. The RC terminals should remain open if not used (see Figure).

The RC terminals are isolated from the AC input and DC output terminals.

3.7 PARALLEL OPERATON

Identical RCW 1500W Power Supplies can be connected in parallel (see Figure 8). The output current of each Power Supply can be balanced by connecting together all the CB terminals, connecting together all the -S terminals and connecting together all the +S terminals of up to four 1500W

Power Supply units (see Figure 8 for three units). The current tolerance with up to four RCW 1500W units in parallel should be within (\pm) 10% of the rated output current. With four RCW 1500W units in parallel, the output voltage of any Power Supply individually must be within 2% of the other power supply output voltages. The output current range is 20 to 90% of the nominal output current.

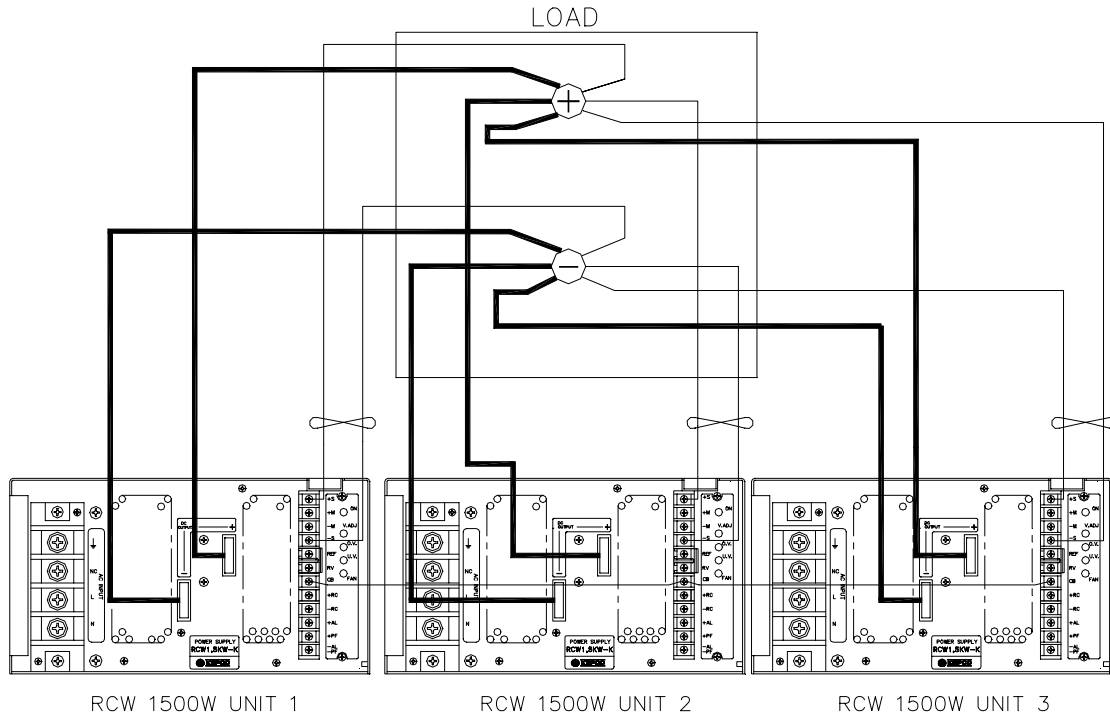

3041594

NOTES

- 1) Remove the connecting links between the (+) M and (+) S terminals and between the (-) M and (-) S terminal. Maintain the connecting links between the REF and RV terminals.
- 2) Set voltage of unit 1 to the desired voltage at the load.
- 3) With three RCW 1500W units in parallel the output voltage of each Power Supply must be set to less than 2% of each other
- 4) When the Current Balance function is used with the Remote ON/OFF function, connect all the (+) RC terminals together and all the (-) RC terminals together.
- 5) Use the same length and wire size for load connecting wires from the (+) and (-) Bus Bar of each RCW 1500W Power Supply to the load terminals
- 6) Use the same length and wire size for twisted pair Sensing wires from the (+) S and (-) S terminals of each RCW 1500W power Supply to the load terminals

FIGURE 8 PARALLEL CONNECTION OF THREE RCW POWER SUPPLIES

The conditions for current equalization are:

$$\frac{\text{Maximum Voltage} - \text{Minimum Voltage}}{\text{Rated Voltage}} = 2\%$$

Output current is 20 to 90% of the total rated output current

The maximum output current: Rated output current x (number of power supplies) x (0.9 max).

Four units are the maximum allowed.

When the current balance function is used together with the Remote ON/OFF function, connect together all the (+) RC terminals and connect together all the (-) RC terminals.

3.8 MASTER/SLAVE OPERATION

To adjust all output voltages at the same time by only one V. ADJ. control on the Master Power Supply (and when using multiple loads), remove the link between the REF to RV terminals on the Slave Power Supplies: Maintain the links between the (+) S and (+) M terminals and between the (-) S and (-) M terminals of the Master and Slave units, and connect all the (-)S terminals together, and connect all the CB terminals together, and all the RV terminals together of the Master and Slave units. Connect all the (+) output terminals to the (+) load terminal, and all the (-) output terminals to the (-) load terminal.

3.9 PRELIMINARY ELECTRICAL CHECK

Connect an adjustable load across the power supply output terminals, on the center bus bars (on the front panel, see Figure 9). The load must have a dissipation rating of at least 3000 Watts. Connect a voltmeter and an oscilloscope across the power supply Monitor terminals, (+) M and (-) M, located on the right side terminal block (on the front panel). The oscilloscope must be isolated from the source and grounded at the load. Use an isolation transformer between the test equipment and the AC input power (see Figure 9).

Connect the AC input power to the line, neutral and ground terminals of the left side terminal barrier strip (on the front panel). Turn the unit ON and check the output voltage with and without load. The output voltage can be adjusted within the published range by using the front panel voltage control trimmer.

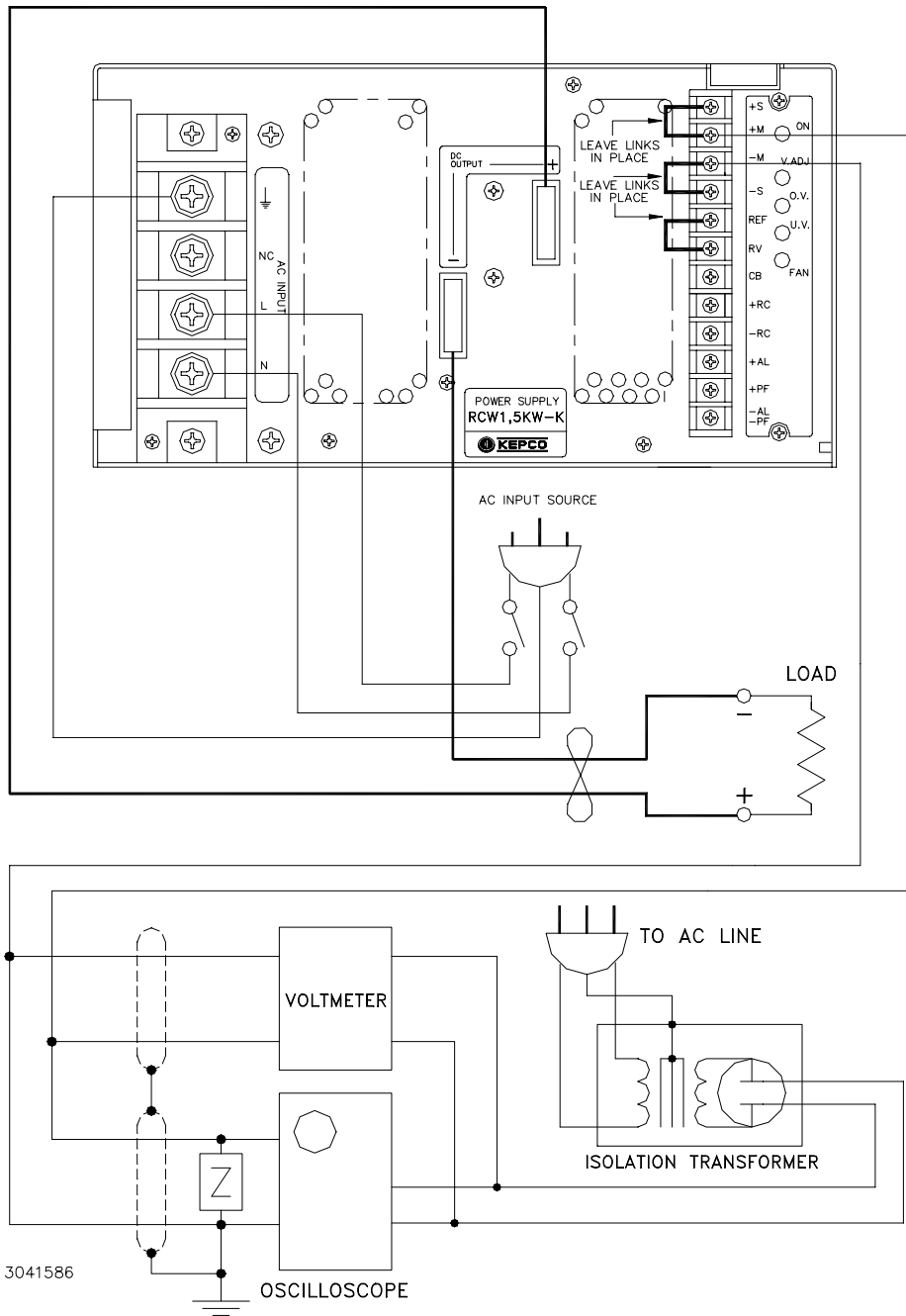
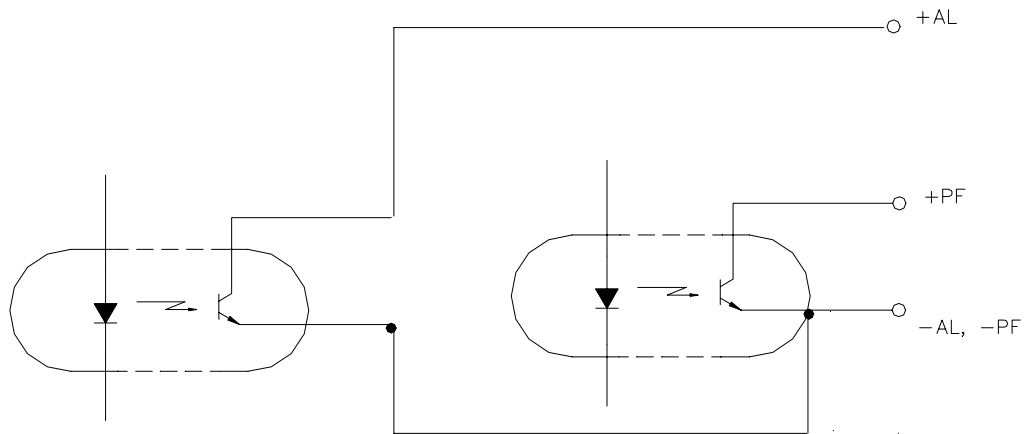

FIGURE 9 FUNCTIONAL CHECKOUT OF THE RCW 1500W POWER SUPPLY

4.0 ALARM FUNCTIONS

4.1 OVERVOLTAGE AND OVERTEMPERATURE PROTECTION

When the output voltage or the internal temperature of the RCW 1500W Power Supply increases beyond the specified values (see Table 2), the output is cut OFF and the fan turns OFF. To restart (reset) the unit it is necessary to remove the AC input power, wait 40 seconds and then to reconnect the AC input power. Another way to reset the power supply is to short circuit the (\pm) RC terminals and then open the terminals. However, when the Power Supply shuts down due to an increase in internal temperature, the restart cycle (Power ON) should not begin until the temperature returns to within specifications. Indication of an overvoltage or overtemperature condition is provided by a red LED and a logic alarm output (at the (\pm) AL terminals) The alarm circuit is a diode transistor optical coupler. The alarm is activated when the collector emitter circuit is open (see Figures 10 and 11).



3041894

FIGURE 10 LOGIC ALARM OPTICAL COUPLER OUTPUT FOR THE RCW 1500W POWER SUPPLY

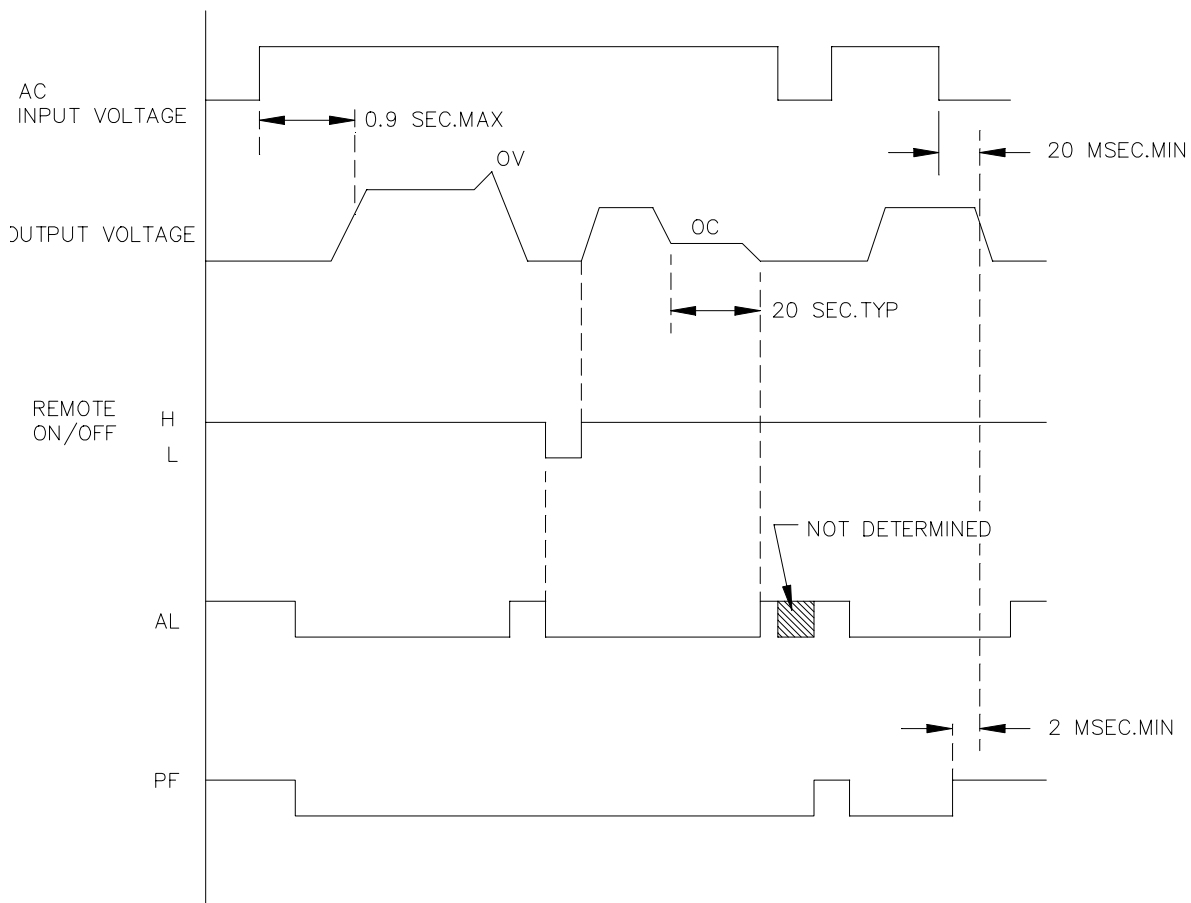

3041273

FIGURE 11 TIMING DIAGRAMS FOR THE RCW 1500W POWER SUPPLY

4.2 UNDERVOLTAGE PROTECTION

When the output voltage falls to less than 60% of the rated output voltage (for more than 20 seconds) the output is cut OFF and the fan stops automatically. To restart (reset) the unit it is necessary to remove the AC input power, wait 40 seconds and then to reapply the AC input power. Another way to reset the power supply is to short circuit the (±) RC terminals and then open the terminals). An indication of undervoltage is provided by a red LED and a logic alarm output (at the (±) AL terminals).

4.3 PF INPUT POWER FAILURE

When the input voltage to the Power Supply falls down, the power failure circuit alarm will be generated for 2ms before the output of the Power Supply is cut off. The input voltage power failure is indicated by a logic alarm output (at the (±) PF terminals).

4.4 FAN FAILURE

A decrease in fan speed causes the output to shut down and the fans to turn OFF. To restart (reset) the unit it is necessary to remove the AC input power, wait 40 seconds and then to reapply the AC input power.

Another way to reset the power supply is to short circuit the (\pm) RC terminals and then open the terminals). Fan failure is indicated by a red LED and logic alarm output (at the (\pm) AL terminals).

5.0 FAN REPLACEMENT

To replace the fans on the back panel of the RCW 1500W Power Supply, the following steps are required:

1. Remove the four Phillips Head screws holding the rear back panel in place (this is the one covering the front of the fan). Pull off the back panel and disconnect the fan connector (CP602 or CP603) from its mating connector. Make sure there are no other wires attached to the fan before removing it from the unit (see Figure 4).
2. When reinstalling the fan in the power supply make sure that the fan connector is securely fastened and that the fan cable does not touch the rotating member of the fan assembly.

6.0 FAN MAINTENANCE

Do not use the fan in an environment of high temperature and high humidity, particularly in one that exceeds the temperature and humidity limits given in the Power Supply Specifications (see Table 2). Avoid an environment where corrosive gas may be present. If the Power Supply is used in an open or dirty area, a filter should be installed on the air intake side of the fan to prevent the inflow of dust particles. If the Power Supply is used in briny air care should be taken to keep the salt from entering the Power Supply.

You must register your product to comply with the terms of the warranty. Either fill out the form below and mail or fax to Kepco, or for rapid on-line registration go to:

<http://www.kepcopower.com/warranty.htm>

PRODUCT PURCHASED:

Model Number) _____

Serial Number _____

PURCHASE INFORMATION:

Date Purchased: _____

Date Received: _____

REQUEST ADDITIONAL INFORMATION

Send complete Catalog

Have Sales Engineer Call

Contact via: E-Mail Telephone Fax S-mail

REGISTER TO:

Registered by: _____

Company Name: _____

Street: _____

City: _____

State: _____

Country: _____

Zip: _____

E-mail: _____

FAX: _____

Phone: _____

WHAT INFLUENCED YOUR CHOICE OF THIS POWER SUPPLY?

Previous Experience (which Kepco Models do you have?) _____

Magazines (which ones?) _____

Trade Shows (which ones?) _____

Directory? _____

Kepco Catalog or Brochure? _____

Sales Representative?

Web Site

Other (please explain): _____

What products would you like to see Kepco make?

CUT HERE

Kepco 5 Year Warranty

This is to certify that we, KEPSCO, INC., (hereinafter called "Company"), Flushing, NY 11352 USA, warrants for a period of FIVE YEARS, this instrument known as:

MODEL: _____

SERIAL NO. _____

The Company's products are warranted for a period of five years from date of delivery to be free from defects in materials and workmanship and to conform to the specifications furnished or approved by the Company. Liability under this warranty shall be limited to the repair or replacement of any defective product at Company's option.

If any defect within this warranty appears within the warranty period, the Purchaser shall promptly notify the Company in writing. No material will be accepted for repair or replacement without written authorization of the Company.

Upon such authorization, and in accordance with instructions of the Company, parts or materials for which replacement is requested shall be returned to the Company for examination, with shipping charges prepaid by the Purchaser. Final determination as to whether a product is actually defective rests with the Company.

This warranty does not extend to any product which has been subjected to misuse, neglect, accident, improper installation, or use in violation of instructions furnished by the Company. The warranty does not extend to, or apply to, any unit which has been repaired or altered outside of the Company's factory by persons not expressly approved by the Company.

THE WARRANTY HEREIN CONTAINED IS IN LIEU OF AND EXCLUDES ALL OTHER WARRANTIES, EXPRESS, IMPLIED OR STATUTORY, INCLUDING WITHOUT LIMITATION THE WARRANTY OF MERCHANTABILITY.

THIS KEPSCO PRODUCT IS WARRANTED FOR FIVE YEARS!

KEPCO, INC. • 131-38 SANFORD AVENUE, FLUSHING, NY 11352 USA • Tel. 718-461-7000 • Fax. 718-767-1102
E-mail: hq@kepcopower.com • URL: <http://www.kepcopower.com>



FOLD HERE

Please
place
stamp
here

KEPCO, INC.

131-38 SANFORD AVE.
FLUSHING, NY 11352 USA

CUT HERE